



Series
AVU

Air Velocity Transmitter

Ideal for Building Automation Systems



Air Velocity

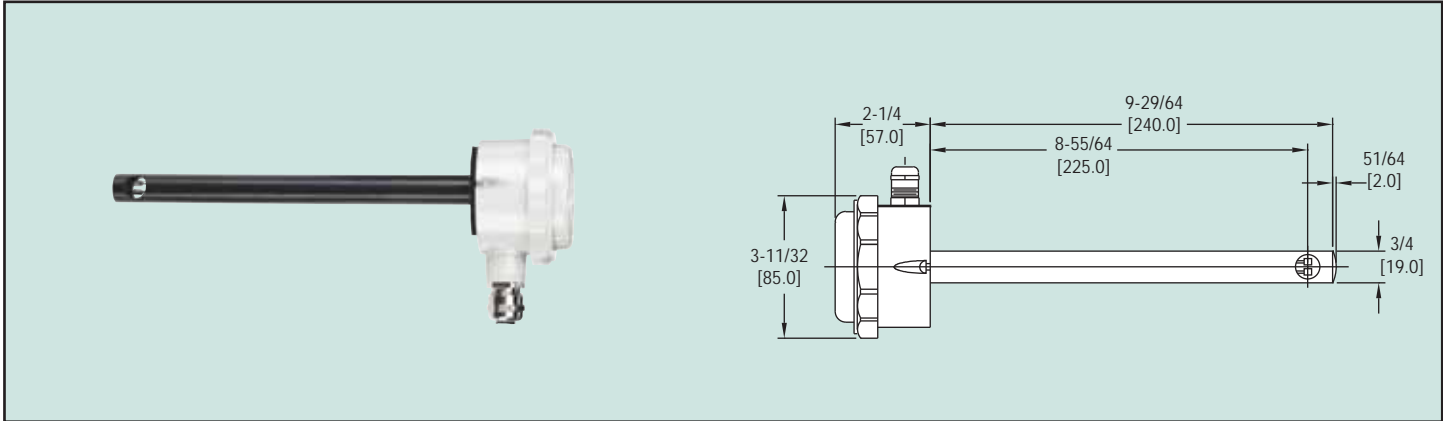

The Series AVU Air Velocity Transmitter is ideal for a wide range of HVAC measurement and control applications, particularly in complete building control and energy management systems. The Series AVU offers 5% accuracy at a surprisingly low cost, with six units covering ranges from 0-785 fpm to 0-3150 fpm, with either 4-20 mA or 0-10 VDC output.

The Series AVU Transmitter operates by measuring the heat loss from one of the two sensing elements in the air stream, then calculating the air velocity. Units are virtually immune to drift due to the design of the sensing element, which makes the transmitter accurate over the whole air velocity range.

FEATURES

- 4-20 mA or 0-10 V Output Versions
- NEMA 6 (IP67) Enclosure Rating
- AC or DC Powered (Loop Version DC Only)
- 5% Accuracy

APPLICATIONS

- Supply and Exhaust Fan Tracking
- Clean Room Systems
- Air Pollution Studies and Manufacturing
- Process Control Systems

SPECIFICATIONS

Service: Clean air and compatible, non-combustible gases.

Accuracy: ±5% of full scale.

Response Time (90%): 5 sec (typical).

Temperature Limits: 32 to 122°F (0 to 50°C).

Humidity Limit: 0-90% RH, non-condensing.

Power Requirements: -A models 24 VDC +10% -15%; -V models 24 VDC or 24 VAC +10% -15%.

Output Signal: -A models 4-20 mA current loop; -V models 0-10 VDC.

Loop Resistance: (-A models) 700 ohms.

Current Consumption: 60 mA + output current.

Max. Start Up Current: 85 mA; 10 V.

Output Current Limit: (-V models) >10 mA.

Electrical Connections: Screw terminal. Cable gland for 4-8 mm wire (16 gauge wire).

Enclosure Rating: NEMA 6 (IP67) except sensing point.

Probe Dimensions: 9.45 x .75" (240 x 19 mm).

Mounting Orientation: Unit not position sensitive. Probe must be aligned with airflow.

Weight: 8.8 oz (250 g).

Agency Approvals: CE.

Model	Range	Output
AVU-1-A	0-785 fpm (0-4 m/s)	4-20 mA
AVU-2-A	0-1575 fpm (0-8 m/s)	4-20 mA
AVU-3-A	0-3150 fpm (0-16 m/s)	4-20 mA
AVU-1-V	0-785 fpm (0-4 m/s)	0-10 VDC
AVU-2-V	0-1575 fpm (0-8 m/s)	0-10 VDC
AVU-3-V	0-3150 fpm (0-16 m/s)	0-10 VDC