

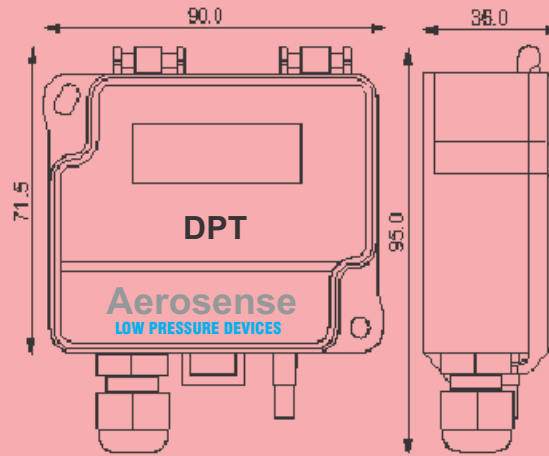

AEROSENSE DIFFERENTIAL PRESSURE TRANSMITTER



Image for DPT-R8-3W-D



Zero-point adjustment

Note! Supply voltage must be connected one hour before the 0-point adjustment is carried out.

- 1) Loose both tubes from the pressure inlets + and –
- 2) Push zero button until the red led turns ON.
- 3) Wait until LED turns off and then install tubes again to the pressure inlets.

It is recommended to adjust the zero point every 12 months during normal operation.

* If the transmitter is equipped with automatic zero element the manual push button adjustment is not required.

Optional auto zero element

AZ-calibration is a function in the form of an automatic zeroing circuit built into the PCB. The AZ-calibration electronically adjusts the transmitter zero at predetermined time intervals (every 10 minutes). The AZ-calibration eliminates all output signal drift due to thermal, electronic or mechanical effects, as well as the need for technicians to remove high and low pressure tubes when performing initial or periodic transmitter zero point calibration.

The AZ adjustment takes 4 seconds. To avoid conflict with the BAS system, the output and display values will freeze to the latest measured value, after which the device returns to its normal measuring mode. Transmitters equipped with the AZ-calibration are virtually maintenance free.

Technical data

Service: Air and non-aggressive gases

Measuring element: Piezoresistive

Accuracy: ±0.8%, or (±1% <250 Pa)

Measuring unit: Selectable by jumper (Pa, kPa, mbar, inchWC, mmWC, psi)

Response Time: 0.8 / 4 s selectable by jumper

Max pressure: 400 kPa

Electrical interface:

- Supply voltage: 24 VAC or VDC ± 10%
- Power consumption: <1.0 W (<1.5W with Iout 20mA)

Output signal:

0...10 VDC, Load R minimum 1kΩ or

4...20 mA, maximum load 500Ω

Materials:

- Housing: ABS
- Cover: PC
- Pressure connections: ABS

Connections:

- Electrical connections: 4 screw terminals, max 1.5 mm²
- Cable entry: M16
- Pressure connections: Male 5,0 mm and 6,3 mm

Weight: 150 g

Dimensions: 90,0 x 71,5 x 36,0 mm

General ambient condition:

- Temperature range:
 - Operation -10...+50°C (-5...+50°C for –AZ model)
 - Storage: -20...+70°C
- Ambient humidity: 0 to 95% RH

Safety:

- Protection standard: IP54
- Conformance: Meets the requirements for CE marking:
 - EMC directive 2004/108/EY
 - Rohs Directive 2002/95/EY

Optional Accessories:

- Plastic Pressure Tips
- 2m Tubes

	Model DPT250-R8-3W	Model DPT2500-R8-3W	Model DPT7000-R8-3W
Measuring Ranges	0-25 Pa	100-0-100 Pa	0-1000 Pa
	0-50 Pa	0-100 Pa	0-1500 Pa
	0-100 Pa	0-250 Pa	0-2000 Pa
	0-250 Pa	0-500 Pa	0-2500 Pa
	25-0-25Pa	0-1000 Pa	0-3000 Pa
	50-0-50 Pa	0-1500 Pa	0-4000 Pa
	100-0-100 Pa	0-2000 Pa	0-5000 Pa
	150-0-150 Pa	0-2500 Pa	0-7000 Pa

Add - **D** to end of Model with Display For e.g. DPT250-R8-3W-D

Add - **AZ** to end of Models with Auto-Zero facility For e.g. DPT250-R8-3W-AZ

Add - **AZ - D** to end of Models with Display and Auto-Zero facility For e.g. DPT250-R8-3W-AZ-D

Installation

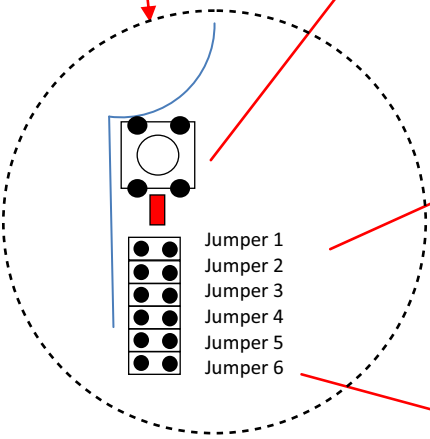
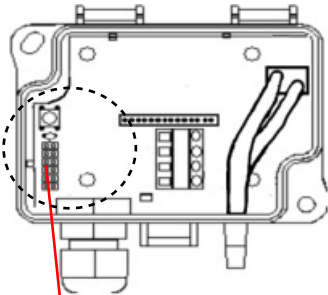
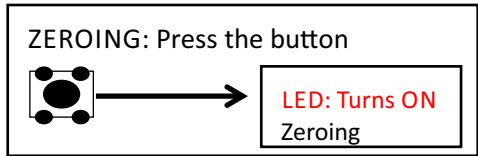

Electrical Connection:

- 0-10V Output 0...10 V
- 4-20mA Output 4...20 mA
- 24V Supply 24 VAC or VDC
- GND Ground

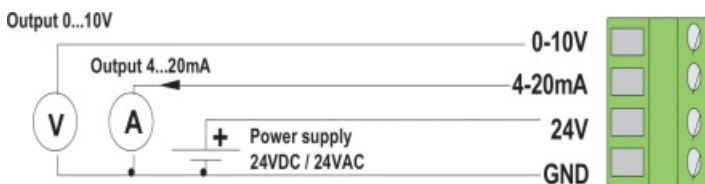

Model DPT250

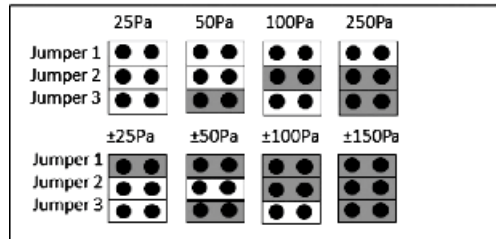

Model DPT2500

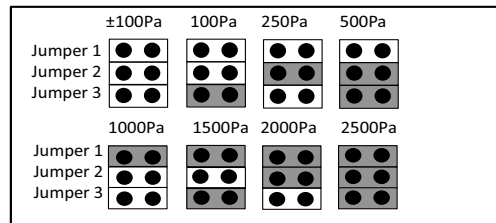

Model DPT7000

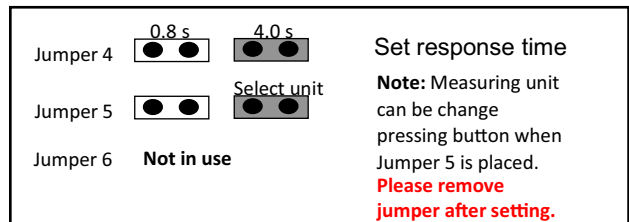
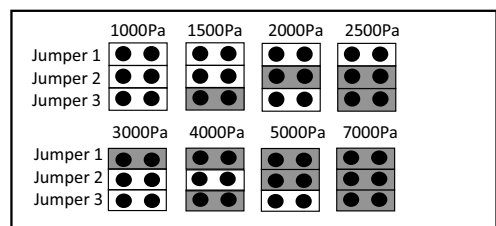

⚠ Note! If wires are already powered, connect 24V and GND before connecting outputs!